

# Mountfield

## Mountfield 550 SP TRI-CUT Owner's Manual

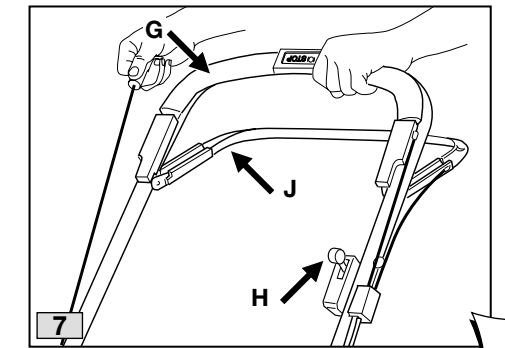

Call our Helpline if you have any problems:  
Helpline Number  
0870 240 2114  
Open from 9:00am to 4:00pm daily

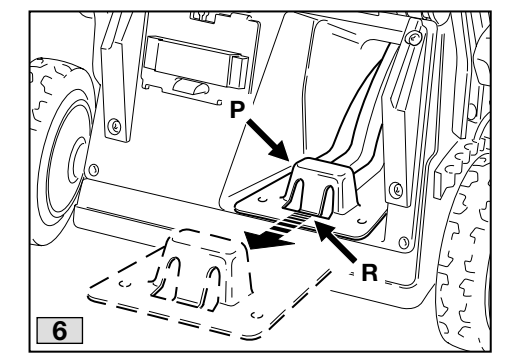
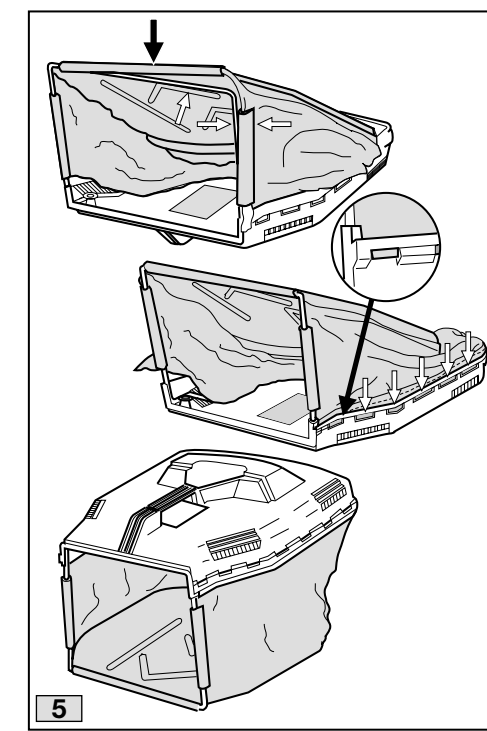
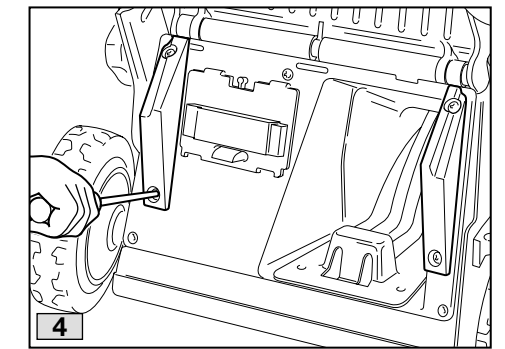
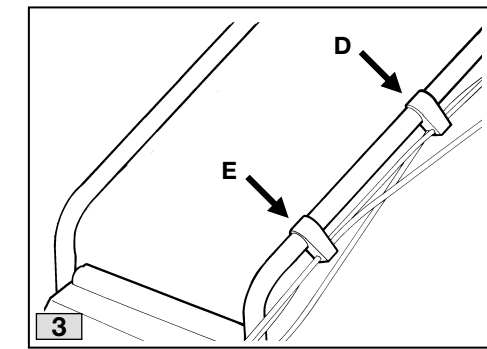
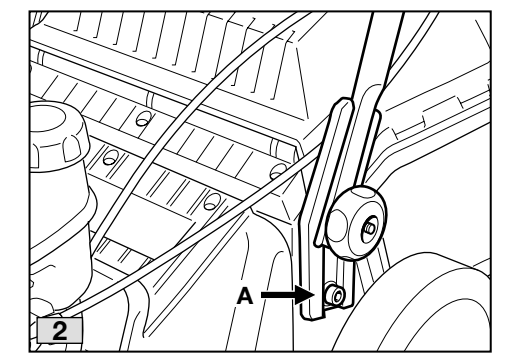
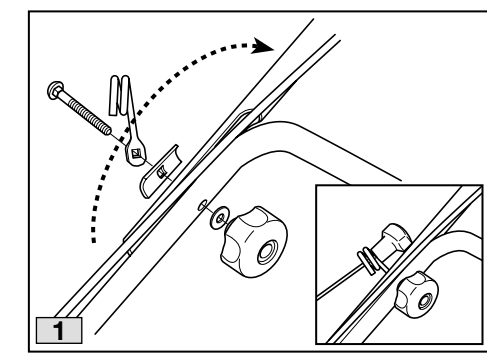

Model: .....  
Type: .....  
(Year) ..... S/N° .....

LWA  
dB  
CE

TUV Rheinland GS

### Mountfield

Manufactured by:  
GGP ITALY SPA - Via del Lavoro, 6 - 31033 Castelfranco Veneto (TV) - ITALY

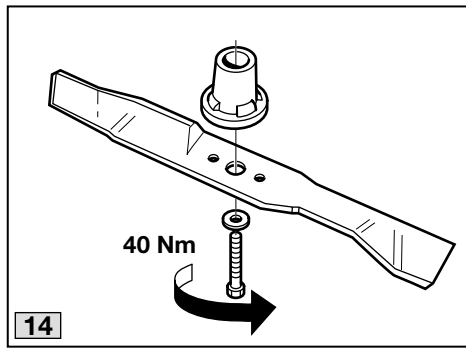
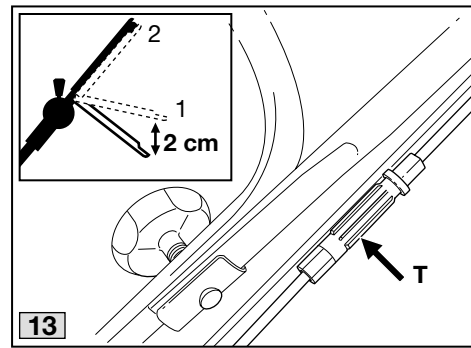
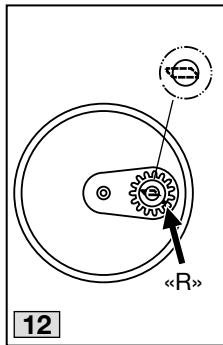
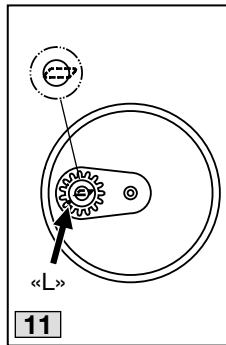
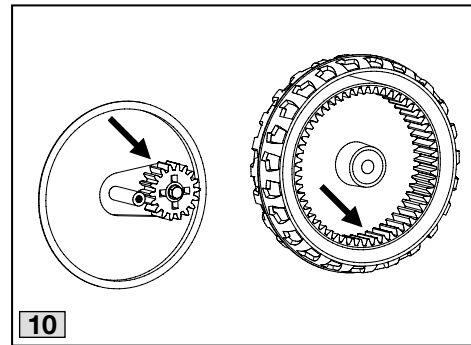
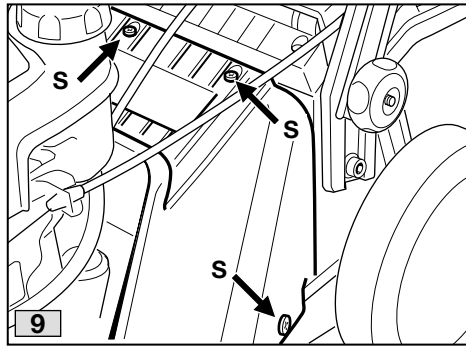
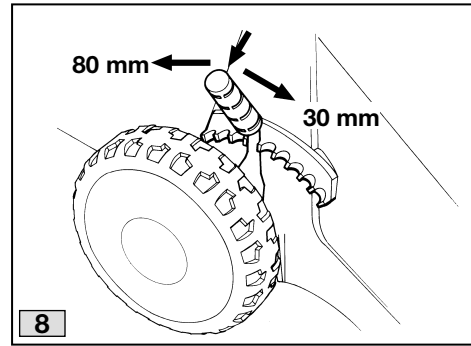

## SAFETY REGULATIONS

### A) TRAINING

- 1) Read the instructions carefully. Get familiar with the controls and proper use of the equipment. Learn how to stop the engine quickly.
- 2) Only use the lawnmower for the purpose for which it was designed, i.e. for cutting and collecting grass. Any other use can be hazardous, causing damage to the machine.
- 3) Never allow children or people unfamiliar with these instructions to use the lawnmower. Local regulations may restrict the age of the operator.
- 4) Never use the lawnmower:
  - When people, especially children, or pets are nearby.
  - If the operator has taken medicine or substances that can affect his ability to react and concentrate.
- 5) Remember that the operator or user is responsible for accidents or hazards occurring to other people or their property.

### B) PREPARATION

- 1) While mowing, always wear sturdy footwear and long trousers. Do not operate the equipment when barefoot or wearing open sandals.
- 2) Thoroughly inspect the area where the equipment is to be used and remove all objects which may be thrown by the machine or damage the cutter assembly and the engine (stones, sticks, metal wire, bones, etc.)
- 3) **WARNING: DANGER!** Engine fuel is highly flammable:
  - Store fuel in containers specifically designed for this purpose.
  - Refuel using a funnel and outdoors only. Do not smoke while refuelling or whenever handling the fuel.
  - Add fuel before starting the engine. Never remove the cap of the fuel tank or add fuel while the engine is running or when the engine is hot.
  - If fuel is spilled, do not attempt to start the engine but move the machine away from the area of spillage and avoid creating any source of ignition until the fuel has evaporated and the vapour dispersed.
  - Replace all fuel tanks and containers caps securely.
- 4) Substitute faulty silencers.
- 5) Before use, always inspect the machine, especially the condition of the blades, and check that the screws and cutting assembly are not worn or damaged. Replace worn or damaged blades and screws in sets to preserve balance.
- 6) Before mowing, attach the discharge opening guards (grass-catcher or stone-guard).

### C) OPERATION

- 1) Do not operate the engine in a confined space where dangerous carbon monoxide fumes can collect.
- 2) Mow only in daylight or good artificial light.
- 3) If possible, avoid operating the equipment in wet grass.
- 4) Always be sure of your footing on slopes.
- 5) Walk, never run and do not allow yourself to be pulled along by the lawnmower.
- 6) Mow across the face of slopes, never up and down.
- 7) Exercise extreme caution when changing direction on slopes.
- 8) Do not mow on slopes of more than 20°.
- 9) Exercise extreme caution when pulling the lawnmower towards you.
- 10) Stop the blade if the lawnmower has to be tilted for transportation when crossing surfaces other than grass, and when transporting the lawnmower to and from the area to be mowed.
- 11) Never operate the lawnmower with defective guards, or without safety devices, such as the stone-guard and/or grass-catcher, in place.
- 12) Do not change the engine governor settings or overspeed the engine.
- 13) On power-driven models, disengage the drive clutch before starting the engine.
- 14) Start the engine carefully, following the instructions and keeping feet well away from the blade.
- 15) Do not tilt the lawnmower when starting the engine. Start the engine on a flat surface that is free of obstacles and tall grass.
- 16) Do not put hands or feet near or under rotating parts. Keep clear of the discharge opening at all times.
- 17) Never pick up or carry a lawnmower while the engine is running.
- 18) Stop the engine and disconnect the spark plug wire:
  - Before carrying out any work underneath the cutting deck or before unclogging the chute;
  - Before checking, cleaning or working on lawnmower;
  - After striking a foreign object. Inspect the lawnmower for damage and make repairs before restarting and operating the lawnmower;
  - If the lawnmower starts to vibrate abnormally (find and remove the cause of the vibration immediately).
- 19) Stop the engine:
  - Whenever you leave the lawnmower unattended. Remove the key from models with electric starters.
  - Before refuelling.
  - Every time you remove or replace the grass-catcher.
  - Before adjusting the cutting height.
- 20) Reduce the throttle before turning off the engine and turn the fuel off when you have finished mowing, following the instructions in the engine handbook.
- 21) When mowing, always keep to a safe dis-

tance from the rotating blade. This distance is the length of the handle.

#### D) MAINTENANCE AND STORAGE

- 1) Keep all nuts, bolts and screws tight to be sure the equipment is in safe working condition. Regular maintenance is essential for safety and performance.
- 2) Never store the equipment with fuel in the tank inside a building where vapour may reach a flame or a spark or a source of extreme heat.
- 3) Allow the engine to cool before storing in an enclosed space.
- 4) To reduce the fire hazard, keep the engine, exhaust silencer, battery compartment and fuel storage area free of grass, leaves, or excessive grease. Do not leave containers with grass cuttings in rooms.
- 5) Check the stone-guard and grass-catcher frequently for wear and deterioration.
- 6) If the fuel tank has to be drained, this should be done outdoors and when the engine is cool.
- 7) Wear strong work gloves when removing and reassembling the blade.
- 8) Check the blade's balance after sharpening.
- 9) For reasons of safety, do not use the equipment with worn or damaged parts. Parts are to be replaced and not repaired. Use genuine spare parts (blades should always bear the symbol  $\Delta$ ). Parts that are not of the same quality can damage the equipment and be dangerous for your safety.
- 10) Whenever the machine is to be handled, transported or tilted you must:
  - wear strong working gloves;
  - grasp the machine at the points that offer a safe grip, taking account of the weight and its distribution.

- Do not dispose of used lead-acid batteries in a rubbish bin. Take them to a battery collection point for recycling (applies to battery-powered machines and machines with battery start).
- Replace the silencer if faulty. When carrying out repairs, always use original spare parts.
- If the machines were originally equipped with a catalyser which is now faulty, a new one must be fitted when the silencer is replaced.
- Always seek professional help when the carburettor requires adjustment.
- Clean the air filter according to the directions.
- When, after many years of service, your machine needs to be replaced or is no longer required, we recommended that the machine is returned to your distributor for recycling.

#### PRODUCT IDENTITY

The identity of the product is determined by the article and serial numbers of the machine.

These can be found on the label fixed to the chassis of the machine:

ART. NR →  
SERIE NR.

Model: .....	CE	LWA
Type: .....	$\Delta$ GS	
(Year): ....	S/N° .....	

Use this identification whenever you contact a service workshop or buy replacement parts.

As soon as possible after buying the machine, write the above numbers on the back page of this booklet.

The manufacturer reserves the right to make changes to the product without prior notice.

#### THE ENVIRONMENT

In order to protect the environment, we recommend that the following points should be given special consideration:

- Always use pure unleaded petrol.
- Always use a funnel and/or a petrol can with a level control to avoid spillage when refilling the fuel tank.
- Do not fill the fuel tank completely.
- Do not overfill with engine and/or transmission oil.
- When changing the oil, ensure that all the used oil is collected. Avoid spillage. Take the used oil to a recycling unit.
- Do not dispose of used oil filter in a rubbish bin. Take it to a recycling unit.

## IMPORTANT

For the instructions relative to the engine and the battery, please read the relevant instruction handbooks.

## SYMBOLS

The following symbols can be found on the machine to remind you of the care and attention that are required during use.

The symbols mean:



Important: Read the instruction handbook before using the



Warning! Keep onlookers away. Beware of objects being flung out.



Warning! Keep hands and feet clear of the cutting deck when the machine is running.



Warning! Before starting any repair work, remove the spark plug cable from the spark plug.



Warning! Always tilt the lawnmower backwards when cleaning the underside. Petrol and oil can run out if the lawnmower is tilted in the other direction.

## INTRODUCTION

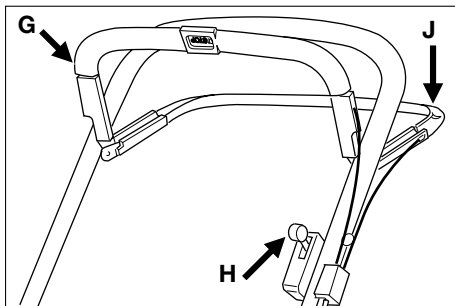

- G** Start/Stop loop  
**H** Throttle control  
**J** Clutch loop

## INSTALLATION

### LOOSE PARTS IN THE BOX

- 2 brackets for the grass collector
- 4 screws for the brackets
- 1 Allen key
- 1 socket wrench
- + Instruction books

### HANDLE

1. Fold up the lower part of the handle.
2. Secure the upper part of the handle with washers and locking wheels. There is a lug on the right hand side for the starter handle (fig. 1).
3. Then tighten the locking wheels onto the lower part of the handle. When these have been tightened, the height of the handle can be adjusted by tightening the screws **A** with the wrench provided. (fig. 2)

### CABLE HOLDER

Secure the cables in the cable holders (fig. 3):

- D:** Start/Stop cable + Clutch cable  
**E:** Throttle cable + Clutch cable

### GRASS COLLECTOR

Raise the collector flap and attach the two brackets to the grass collector with the screws provided. The brackets are marked with «L» and «R» and should be installed at the corresponding mark on the rear of the mower (fig. 4).

Fit the fabric bag over the steel frame and then snap the bag onto the plastic lid (fig. 5).

Open the flap on the machine and attach the grass collector to the brackets.

NOTE! The lawnmower can be operated without the grass collector. The grass is then left in a line behind the machine.

## USING THE MOWER

### COMBI

Your new lawnmower combines two different functions in the same machine:

1. "MULCHING"

The machine comes equipped with a plug (**P**), installed in the ejector opening (fig. 6). The machine

can be used for 'Mulching' i.e. the blade finely cuts up the grass during mowing. The grass then falls into the lawn where it is allowed to rot. This provides the lawn with nourishment. To remove the plug, press in the catch (**R** - fig. 6). On reinstalling the plug ensure that both pins are pressed firmly into the holes so that the plug snaps in place.

## 2. COLLECTION

Assemble the grass collector provided (fig. 5). Open the flap, remove the plug and instead hook the collector onto the rear of the machine. When mowing, the grass is collected in the collector. Empty the grass onto the compost heap or spread it over borders as fertiliser. The machine is also ideal for collecting up leaves in the autumn.

## 3. REAR EJECTION

Use the mower without the plug or the grass collector (flap closed). The grass is released behind the machine without being cut up.

## STARTING THE ENGINE

1. Place the lawnmower on flat, firm ground. Do not start in long grass.
2. Make sure the spark plug cable is connected to the spark plug.
3. Press in the Start/Stop loop **G** towards the handle. NOTE! The Start/Stop loop **G** must be kept pressed in to prevent the engine stopping (fig. 7).
4. Grasp the starter handle and start the engine by pulling briskly on the starter cord.
5. For the best mowing results, the engine should always be driven at full throttle.

## STOPPING THE ENGINE



**The engine may be very warm immediately after it is shut off. Do not touch the silencer, cylinder or cooling flanges. This can cause burn injuries.**

Release the Start/Stop loop **G** (fig. 7) to stop the engine.



**If the start/stop loop ceases to work, stop the engine by removing the spark plug cable from the spark plug. Immediately take the lawn mower to an authorised workshop for repair.**

## REAR WHEEL DRIVE (\*)

Engage the drive by pressing the clutch loop **J** towards the handle. Disengage the drive by releasing the clutch loop **J** (fig. 7).

## CUTTING HEIGHT



**Do not set the cutting height so low that the blade(s) come into contact with uneven ground.**

The mower has single-lever control for adjusting the cutting height. Pull the lever out, and set the cutting height to one of the nine positions best suited to your lawn (fig. 8).

---

## MAINTENANCE

---

**IMPORTANT – Regular, careful maintenance is essential for keeping the safety level and original performance of the machine unchanged in time.**

Wear strong working gloves during any cleaning, maintenance or adjustment operation on the machine.

Should it be necessary to access the lower part, only tilt the machine from the side shown in the engine handbook; following the relative instructions.

## CLEANING

Carefully clean the machines with water after each cut; remove the grass debris and mud accumulated inside the chassis to avoid their drying and thus making the next start-up difficult.

The paintwork on the inside of the chassis may peel off in time due to the abrasive action of the cut grass; in this case, intervene promptly by touching up the paintwork using a rustproof paint to prevent the formation of rust that would lead to corrosion of the metal.

Remove the transmission casing by removing the screws **S** (fig. 9) and clean around the transmission and drive belts with a brush or compressed air once or twice a year.

Once every season, the drive wheels should be cleaned internally. Remove both wheels.

Clean the gear wheel and the wheel gear rim of grass and dirt using a brush or compressed air (fig. 10).

## LUBRICATING DRIVE SHAFT

Once per season, the wedge on the drive shaft should be greased. Remove the wheel (wheel cap, screw and washer).

Then remove the circlip and washer so that the gear wheel can be removed from the shaft. Lubricate the wedge with universal grease.

Reinstall the wedge (the wedge is installed differently on the right and left side, fig. 11 - 12). Install the gear wheel so that the «L» faces out on the left side and the «R» faces out on the right side (machine viewed from the rear).

## ADJUSTING CLUTCH CABLE

If the drive does not engage when the clutch loop is pressed against the handle, or if the lawnmower feels cumbersome or slow, this may be because the clutch in the transmission is slipping.

To rectify this situation, adjust the clutch cable as follows (with the engine off):

1. When the clutch loop is released, it should be possible to push the mower backwards without any resistance. If this is not the case, screw in the nipple **T** until the mower can be pushed (fig. 13).
2. When the clutch loop is pressed in approx. 2 cm (position 1), there should be some resistance when pushing the lawnmower. With the clutch loop fully pressed in (position 2) it should not be possible to push the mower. Unscrew the nipple **T** until this position is achieved.

## CHANGING BLADES

To replace the blade, undo the screw (fig. 14). Fit the new blade so that the stamped logo is turned up facing the blade holder (not facing the grass).

Reinstall as illustrated. Tighten the screw properly. Tightening torque 40 Nm.  
When replacing the blade, the blade screw should also be replaced.

## SHARPENING THE BLADES

Sharpening of the blades must be done by wet method grinding, using a whetstone or a grindstone.

For safety reasons, the blades should not be sharpened on an emery wheel. A very high temperature could cause the blades to become brittle.

---

## STORAGE

---

The same petrol must not remain in the tank for more than one month.

Thoroughly clean the mower and store it indoors in a dry place.

---

## SERVICING

---

Genuine spare parts are supplied by service workshops and by many dealers.

We recommend that you take the machine to an authorised service station for annual servicing, maintenance and inspection of safety equipment.

For service and spare parts, please contact the dealer where the machine was purchased.



A series of horizontal dotted lines spanning the width of the page, intended for handwriting practice.





A series of horizontal dotted lines spanning the width of the page, intended for handwriting practice.



A series of horizontal dotted lines spanning the width of the page, intended for handwriting practice.